

Legend

- Factory Low voltage Wiring
- Factory Line Voltage Wiring
- Field Low voltage Wiring
- Field Line voltage Wiring
- Printed Circuit Trace
- Optional Wiring
- Optional Block Capacitor
- Circuit Breaker
- Condensate Pan
- Control Board Jumper
- FUSE
- Ground
- High Pressure Switch
- LED
- Low Pressure Switch
- Mate-N-Lock
- Multi Splice Connector
- * Optional
- Overload
- Relay contacts - N.C.
- Relay contacts - N.O.
- Relay / Contactor Coil
- Solenoid Coil
- Splice Cap
- Temperature Switch
- Thermistor
- Wire Nut

NOTES:

1. Compressor and Blower Motor thermally protected internally.
2. All wiring to the unit must comply with NEC and local codes low voltage wiring shall be Class 2 or equivalent.
3. Field Use Only: Transformer wiring is voltage sensitive. Use layout corresponding to the unit voltage.
4. LT1 provides low temperature protection for WATER. When using ANTI-FREEZE solutions, cut JW3 jumper.
6. 24V Alarm signal shown. For Dry Alarm contact between AL1 & AL2, cut JW1 for CXM/DXM Gen2 or JW4 DXM.
7. Transformer Secondary Ground via control board standoffs and/or Common to Control Box.

HYD1. Heat/Cool thermostat wiring shown. Refer to thermostat IOM for wiring to the unit. T-Stat wiring must be "Class 1" and voltage rating equal to or greater than unit supply voltage.

CONTROL BOX LAYOUT

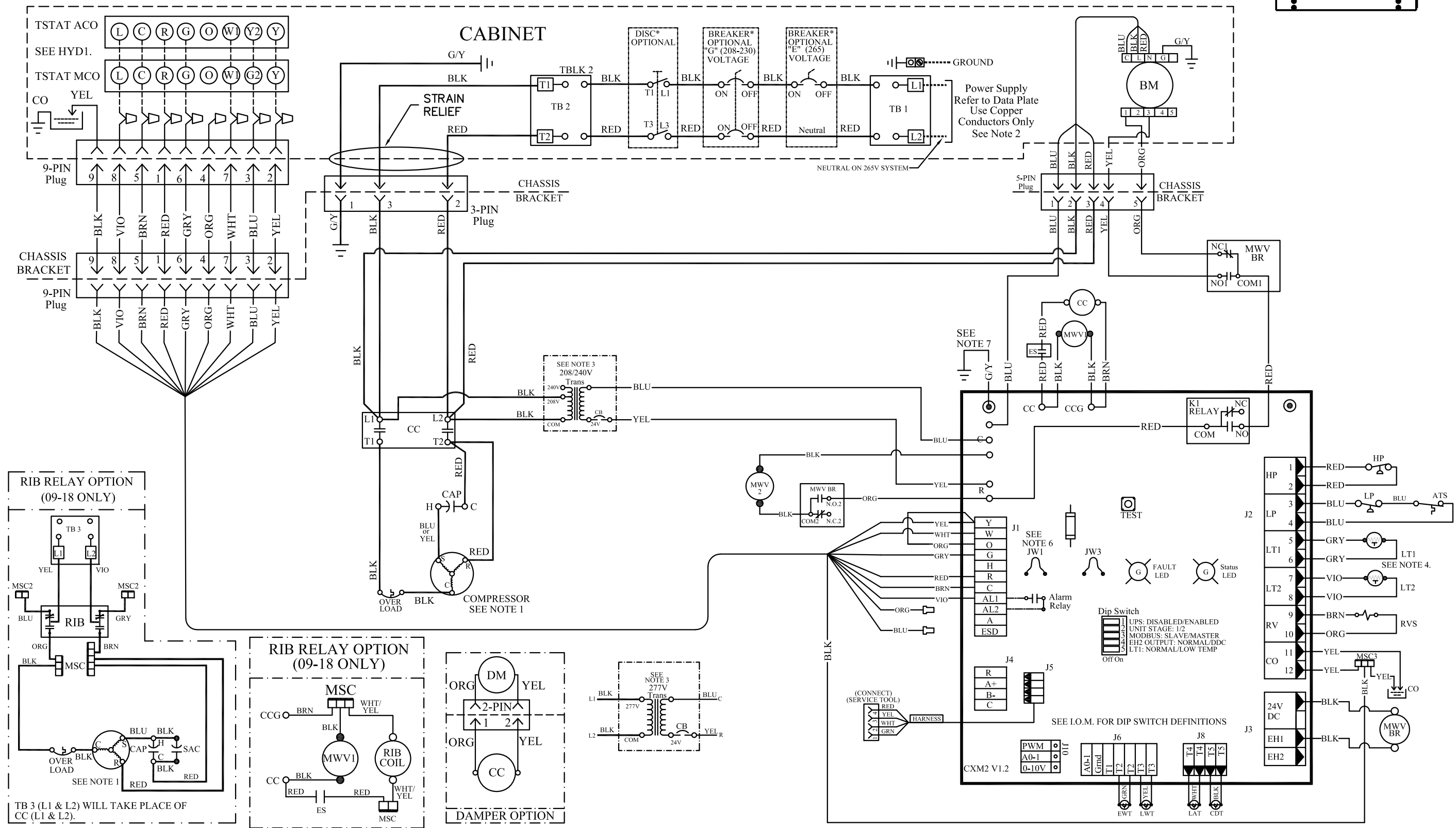
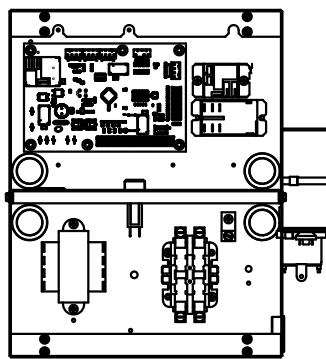

- ACO Automatic Change Over
- AL Alarm Relay Contacts
- ATS Air Temperature Sensor
- BM Blower Motor
- BMC Blower Motor Capacitor
- BR Blower Relay / Blower Contactor
- CAP Capacitor
- CB Circuit Breaker
- CC Compressor Contactor
- CDT Compressor Discharge Temperature
- CO Condensate Overflow Sensor
- CR Compressor Relay
- CRC Compressor Run Capacitor
- CS Current Sensor
- DHW Domestic Hot Water
- DM Damper Motor
- DTS Discharge Temperature Switch
- EEV Electronic Expansion Valve
- EHC Electronic Heat Contactor
- ES End Switch
- ETC Electronic Temperature Control
- EWT Entering Water Temp Sensor
- FSR Fan Speed Relay
- FSS Fan Speed Switch
- HP High Pressure Switch
- HPWS High Pressure Water Switch
- HR Heating Relay
- JW Jumper Wire
- LAT Leaving Air Temperature
- LOR Lock Out Relay
- LP Low Pressure Switch
- LT1 Sensor, low temp protection, water coil
- LT2 Sensor, low temp protection, air coil
- LWT Leaving Water Temp Sensor
- MCO Manual Change Over
- MOD Modulating Water Valve
- MS Manual Starter
- MSC Multi Splice Connector
- MWV Motorized Water Valve
- NLL Night Low Limit Switch
- PDB Power Distribution Block
- POT Potentiometer
- P1 Field Wiring Terminal Block
- PR Pump Relay
- RAS Return Air Sensor
- RVS Reversing Valve Solenoid
- SAC Start Assist Capacitor
- SAS Supply Air Sensor
- TB Terminal Block
- TRANS Transformer
- UMT Unit Mounted Thermostat
- VFD Variable Frequency Drive
- VSP Variable Speed Pump
- WSTAT Water Stat